

DS-3E1510P-E

Gigabit Web-Managed PoE Switch

DS-3E1510P-E switches are layer 2 PoE switches, providing advanced PoE power supply technology and Gigabit networks design on the basis of high-performance access. The switches support Web management, various layer 2 management protocols such as STP/RSTP, VLAN, link aggregation, SNMP, QoS and so on to ensure the data is uploaded steadily.



Key Feature

- 8 × gigabit PoE ports, and 2 × gigabit fiber optical ports.
- IEEE 802.3at/af standard for PoE ports.
- IEEE 802.3, IEEE 802.3u, IEEE 802.3x, IEEE 802.3ab, and IEEE 802.3z standard.
- 6 KV surge protection for PoE ports.
- AF/AT camera can reach up to 300 m in extend mode.
- PoE watchdog to auto detect and restart the cameras that do not respond.
- PoE output power management.
- Gigabit network access design.
- Wire-speed forwarding.
- Store-and-forward switching.
- Various layer 2 management protocols such as STP/RSTP, VLAN, link aggregation, SNMP, QoS and so on.
- Port management.
- Web management.
- Solid high-strength metal shell.
- Reliable fan-free design.



Specification

Model		DS-3E1510P-E
Network parameters	Port number	8 × gigabit PoE ports, and 2 × gigabit fiber optical ports
	Port type	RJ45 port, full duplex, MDI/MDI-X adaptive
	Standard	IEEE 802.3, IEEE 802.3u, IEEE 802.3x, IEEE 802.3ab, and IEEE 802.3z
	Forwarding mode	Store-and-forward switching
	Working mode	Standard mode (default); Extend mode
	MAC address table	8 K
	Switching capacity	20 Gbps
	Packet forwarding rate	14.88 Mpps
	Internal cache	4.1 Mbits
PoE power supply	PoE standard	IEEE 802.3af, IEEE 802.3at
	PoE power pin	Ethernet cables 1/2/3/6 provide power supply.
	PoE port	Ports 1 to 8
	Max. port power	30 W
	PoE power budget	110 W
General	Shell	Metal material, fan-free design
	Net weight	1.21 kg (2.67 lb)
	Gross weight	1.3 kg (2.87 lb)
	Dimension (L × H × D)	217.6 mm × 108.55 mm × 27.8 mm (8.57" × 4.27" × 1.09")
	Operating temperature	-10 °C to 55 °C (14 °F to 131 °F)
	Storage temperature	-40 °C to 85 °C (-40 °F to 185 °F)
	Operating humidity	5% to 95% (no condensation)
	Relative humidity	5% to 95% (no condensation)
	Power supply	48 VDC, 2.5 A
	Power source	120 W
	Max. power consumption	120 W
	Power consumption in idle	7 W
Software function	Device maintenance	Support remote upgrade, recovering default parameters, viewing logs, configuring basic network parameters, import and export configuration, time sync.
	Port configuration	Support the configuration of port rate and slow control, and ports enabling.
	Long range	Support up to 300 m transmission.
	PoE watchdog	Ports 1 to 8: auto detect and restart the cameras that do not respond.
	Port rate-limiting	Support rate-limiting for ingress and egress ports..
	Storm control	Support the storm control of unknown unicast, multicast and broadcast.
	Port mirroring	Support port mirroring function.
	QoS	Support WRR and SP scheduling and port priority.
	VLAN	Support 128 VLANs.
	STP	Support STP and RSTP.
	SNMP	Support SNMPv1 and SNMPv2c, the node information for system and interfaces acquisition.
PoE	Support IEEE 802.3at/af power supply.	

Physical Interface

Front panel:

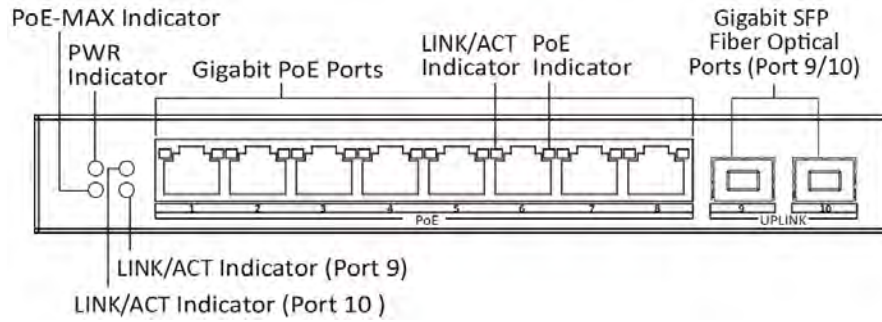

Back panel:

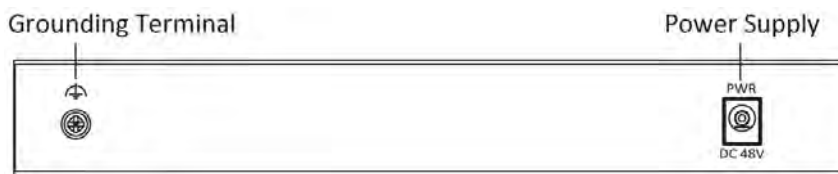

Available Model

DS-3E1510P-E

Dimension (unit: mm)

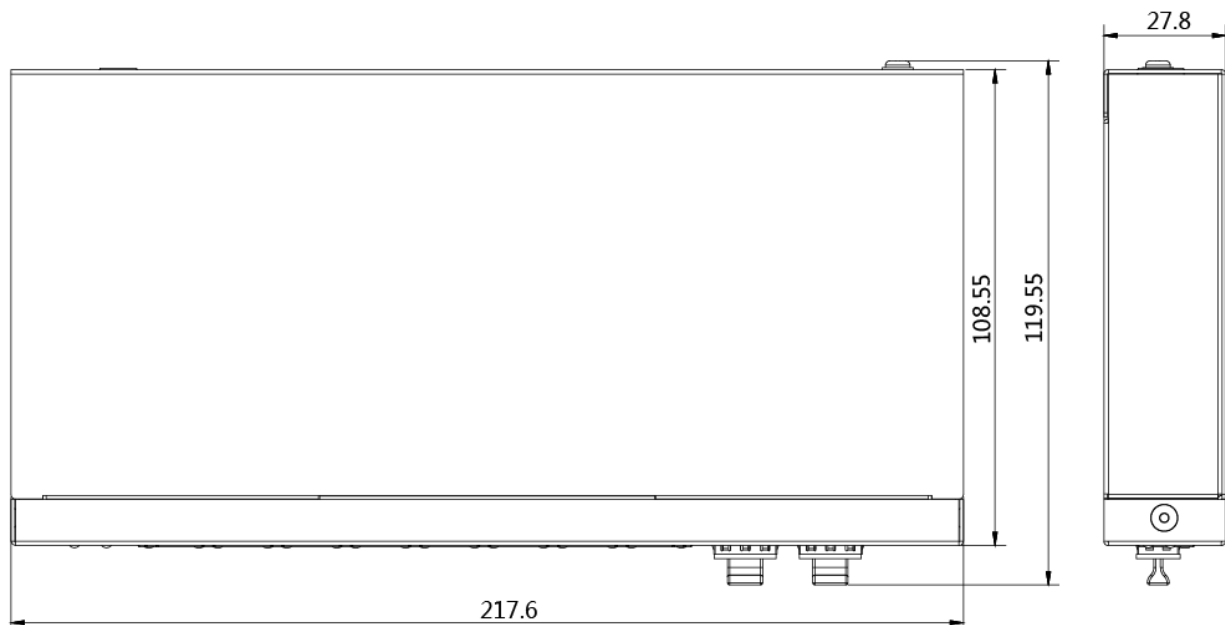

Typical Application

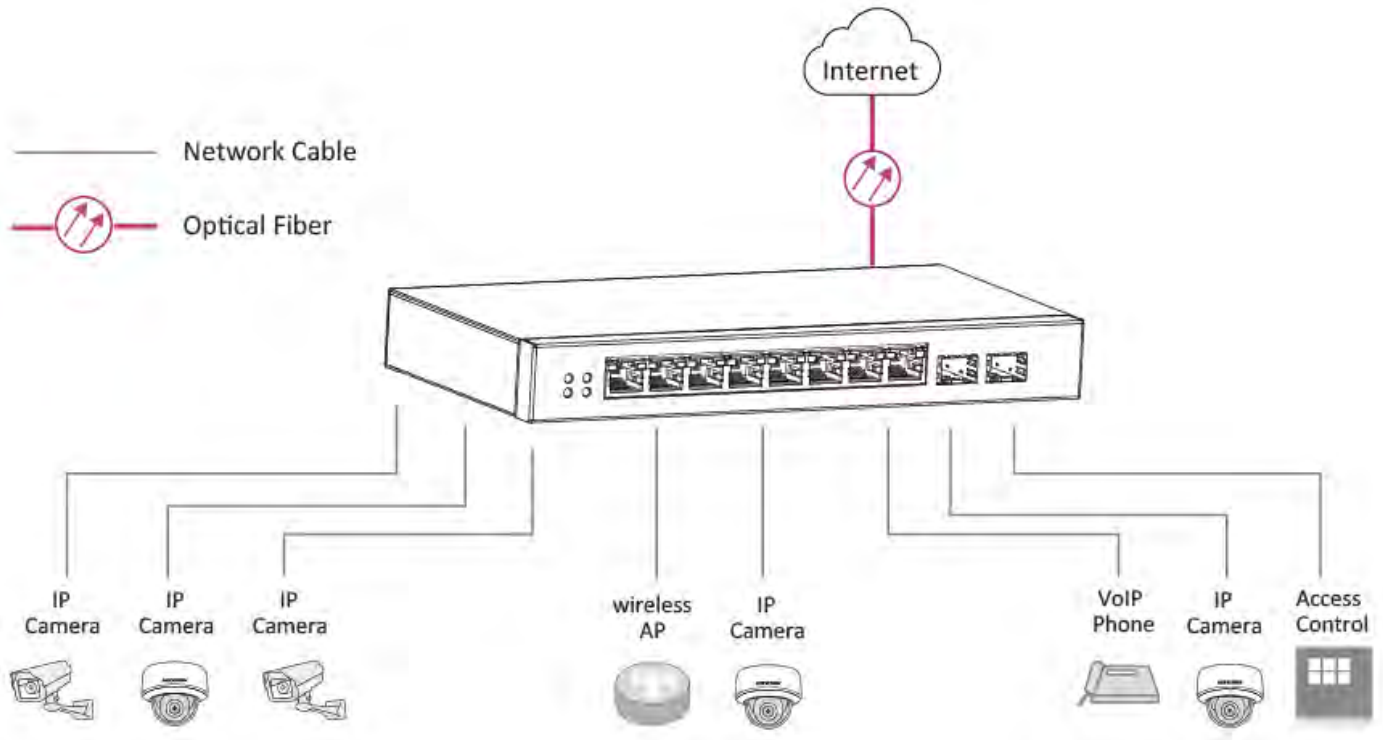

Distributed by



HIKVISION®

Headquarters

No.555 Qianmo Road, Binjiang District,
Hangzhou 310051, China
T +86-571-8807-5998
overseasbusiness@hikvision.com

Hikvision USA
T +1-909-895-0400
sales.usa@hikvision.com

Hikvision Australia
T +61-2-8599-4233
salesau@hikvision.com

Hikvision India
T +91-22-28469900
sales@pramahikvision.com

Hikvision Canada
T +1-866-200-6690
sales.canada@hikvision.com

Hikvision Thailand
T +662-275-9949
sales.thailand@hikvision.com

Hikvision Europe
T +31-23-5542770
sales.eu@hikvision.com

Hikvision Italy
T +39-0438-6902
info.it@hikvision.com

Hikvision Brazil
T +55 11 3318-0050
Latam.support@hikvision.com

Hikvision Turkey
T +90 (216)521 7070- 7074
sales.tr@hikvision.com

Hikvision Malaysia
T +601-7652-2413
sales.my@hikvision.com

Hikvision UK & Ireland
T +01628-902140
sales.uk@hikvision.com

Hikvision South Africa
Tel: +27 (10) 0351172
sale.africa@hikvision.com

Hikvision France
T +33(0)1-85-330-450
info.fr@hikvision.com

Hikvision Kazakhstan
T +7-727-9730667
nikia.panfilov@hikvision.ru

Hikvision Vietnam
T +84-974270888
sales.vt@hikvision.com

Hikvision UAE
T +971-4-4432090
salesme@hikvision.com

Hikvision Singapore
T +65-6684-4718
sg@hikvision.com

Hikvision Spain
T +34-91-737-16-55
info.es@hikvision.com

Hikvision Tashkent
T +99-87-1238-9438
uzb@hikvision.ru

Hikvision Hong Kong
T +852-2151-1761
Info.hk@hikvision.com

Hikvision Russia
T +7-495-669-67-99
saleru@hikvision.com

Hikvision Korea
T +82-(0)31-731-8817
sales.korea@hikvision.com

Hikvision Poland
T +48-22-460-01-50
info.pl@hikvision.com

Hikvision Indonesia
T +62-21-2933759
Sales.Indonesia@hikvision.com

Hikvision Colombia
sales.colombia@hikvision.com