

DS-1696ZJ-Y3(OS)

Pendant Mount

Feature

- Stainless steel with anti-corrosion spray treatment
- With cable outlet(s)

Dimension

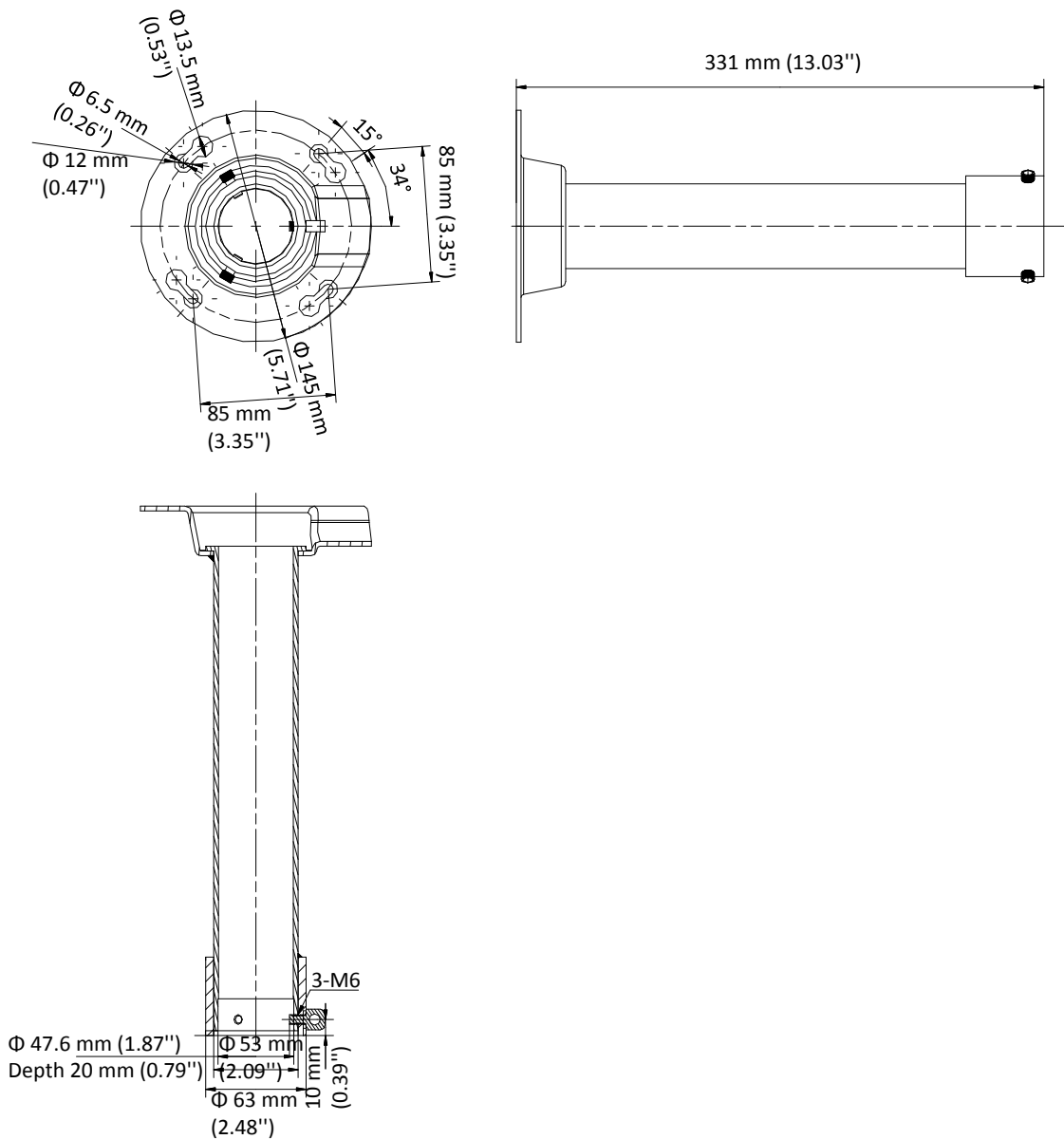
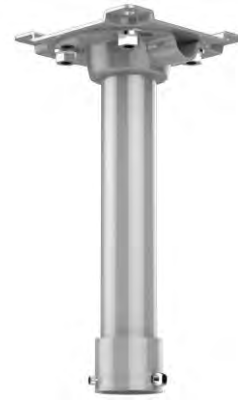

Available Model

DS-1696ZJ-Y3(OS)

Parameter

Model	DS-1696ZJ-Y3(OS)
Parameters	Pendant Mount
Appearance	Silver moon grey
Material	Stainless steel
Dimension	160 mm × 160 mm × 331 mm (6.30" × 6.30" × 13.03")
Weight	Approx. 1892 g (4.17 lb.)

Note

- The mount should be installed on a flat surface.
- Waterproof rubber is necessary for the outdoor application.
- The wall should be capable of supporting at least 3 times as much as the total weight of the camera and the mount.
- The maximum load capacity of the mount is 15 kg (33.07 lb.).